

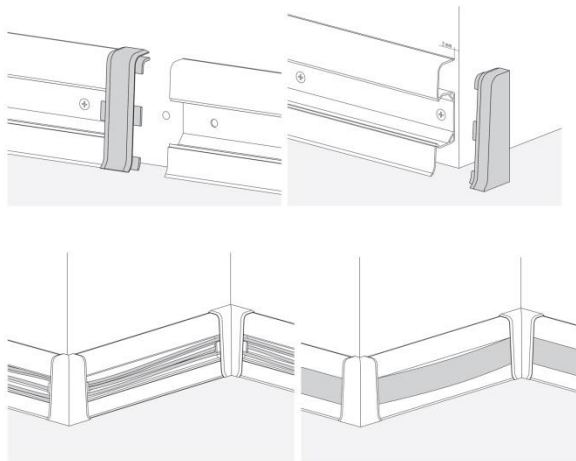

TECHNICAL INFORMATION ESQUERO DUO

Skirting board type	The system of opening installation skirting boards type I CTS
Material	Non-metal skirting boards (made of foamed PVC)
Ensuring electrical continuity	Not ensuring electrical continuity
Way to remove the cover	The cover can be opened without tools.
Impact resistance	1J
Minimum storage and transport temperature	-5°C
Minimum installation and exposure temperature	+5°C
Maximum operating temperature	+60°C
Flame Spread	Non-spreading flame
Insulating properties	Skirting boards with insulating properties
IP	IP20
Rated voltage	to 250V
Useful cross-section	ESQ 6xx – 550mm ²
Equalisation connections	Skirting boards cannot be used to make equalisation connections.
Protection against corrosion and contaminants	High (external and internal)
Electrical protective separation	CTS slats without internal protective barrier
Installation	<p>Skirting boards to be fixed with dowels to a flat wall surface supported against the floor in a horizontal orientation indoors. The ends of the skirting board should be fed into an electrical box, socket or wall, otherwise use a cap. Do not leave the ends of the skirting board unsecured.</p>



Accessories

Internal corner

External corner

Joint



End cap

Quic-fit pin

